

V50P

Quick Installation Guide

English (EN)	2
简体中文 (ZH)	4
Deutsch (DE)	6
Español (ES)	8
Français (FR)	10
Italiano (IT)	12
Português (PT).....	14

English (EN)

Precautions

Warning: Please do not power cycle the device during system boot up or firmware upgrade. You may corrupt firmware images and cause the unit to malfunction.

Warning: Use only the power adapter included in the device package. Using an alternative non-qualified power adapter may possibly damage the unit.

Overview

The V50P is a stylish, high-performance entry-level business IP phone with a 132x64 pixel dot-matrix screen, support for 2 SIP lines and 6-way audio conference, support PoE power supply, and HD voice. It can meet the application scenarios of different enterprises, and provide users with excellent interaction and comfortable instant Internet communication experience.

Packaging list

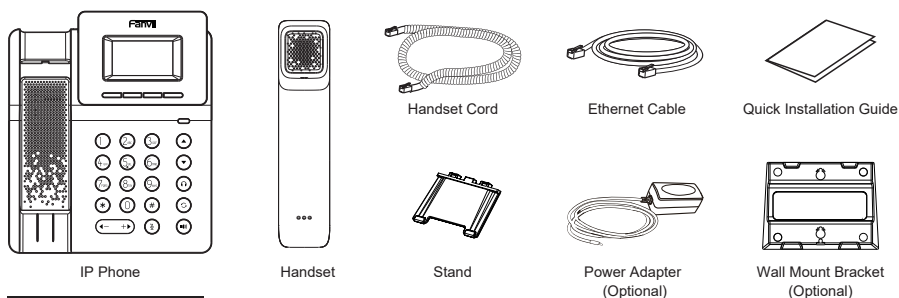

Keys description

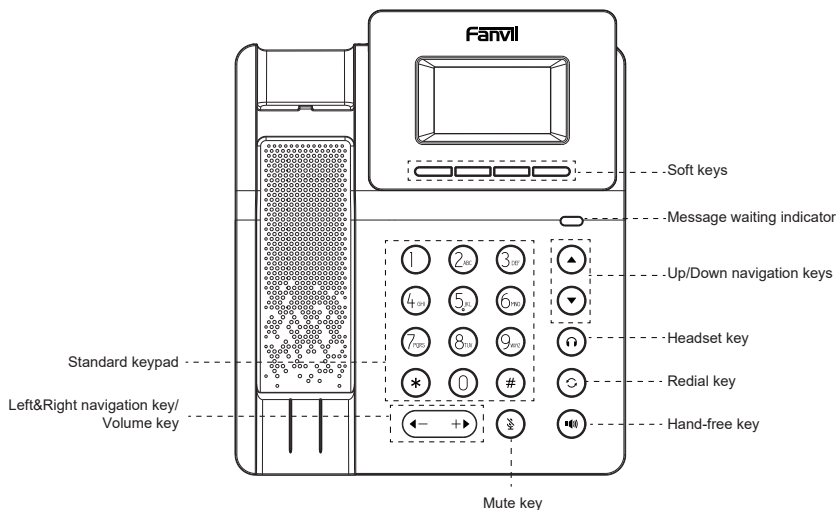

Device Installation

Please follow the instructions in below picture to install the device.

• Desk Mount Method

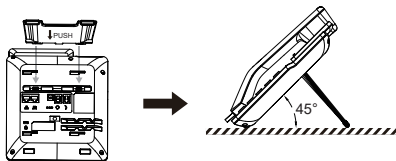
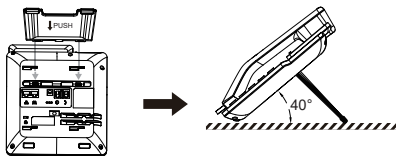

• Wall Mount Method

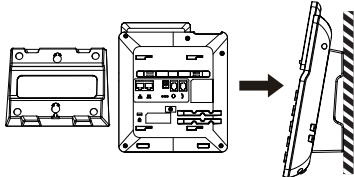

• Connecting to the device

Please connect power adapter, network, PC, handset, and headset to the corresponding ports as described in below picture.

- 1 Power port: connect the power adapter.
- 2 Network port: connect local area network or Internet.
- 3 PC port: the network port connect to the computer.
- 4 Headset port: connect headset.
- 5 Handset port: connect IP Phone handset.

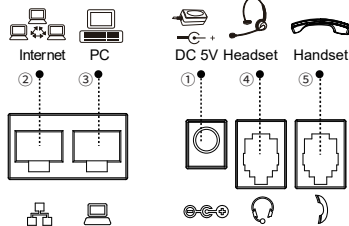

Network connect

Using Ethernet

1. The power on the device and connect the WAN port of the phone to the RJ45 socket of a hub/switch or a router (LAN side of the router) using the Ethernet cable.
2. The default is DHCP mode.

Phone configuration

Configuration via LCD menu of phone

1. Press Menu > Advanced (default password 123).
2. Select Network: To configure the Network Settings (IPv4/IPv6/IPv4&IPv6, DHCP/Static IP/PPPoE) .
3. Select Accounts: To configure enable the account, fill the SIP server address, port, Auth.User, Auth.Password etc.
4. Save the configuration.

Configuration via web

1. Get the IP address from the phone: Menu > Status > ETH IP;
2. Login: Input the IP address in the web browser. The PC and phone should be in the same IP address segment (The default username and password are both 'admin') ;
3. Configure: Select network/account etc, and fill the relevant content ;
4. Save the configuration.

Language setting

1. Press Menu > Basic > Language.
2. Select the desired language and press OK soft key.

Making a call

1. **Pre-dialing**: enter the phone number and pick up the handset.
2. **Direct dialing**: lift the handset and enter the phone number.
3. **Handsfree**: enter phone number and press or vice versa.
4. **Headset**: enter phone number and press or vice versa.
5. **Designated line**: press line key, enter phone number and press dial key.

Accepting a call

1. **Using the handset**: pick up the handset.
2. **Using the headset**: press .
3. **Using the handsfree**: press .

Redial

1. Press key, redial a call number.

Call Mute

1. Press to Mute the microphone during the call.
2. Press again to un-mute the conversation.

Note: You can contact your service provider for additional settings that may be necessary to configure the phone, or download the user manual and FAQ for more detailed information.

简体中文 (ZH)

注意事项

警告: 请不要在设备启动未完成或设备升级软件时断开电源, 因为如刚才所述的操作将会导致话设备本身的程序损坏, 进而导致设备无法启动。

警告: 请使用设备包装中的电源适配器, 因为使用其他没有经过认证的替代电源适配器有可能对设备造成损害。

产品概览

V50P是一款外观时尚的高性能入门级网络话机, 采用132x64分辨率黑白点阵屏, 支持2条SIP线路和6方语音会议, 支持PoE供电, 具有高清语音。可满足不同企业的应用场景, 为用户提供卓越的交互和舒适的即时互联互通体验。

包装清单

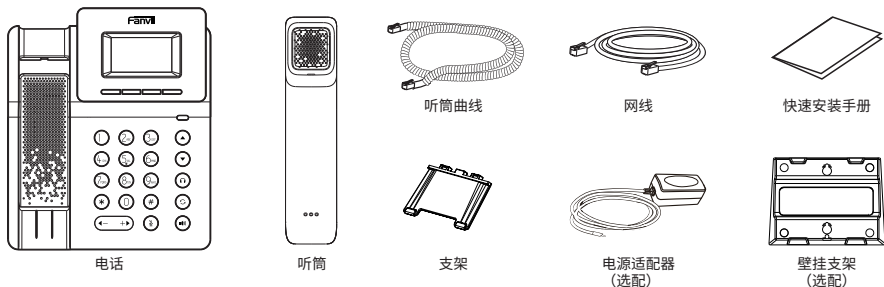

按键概览

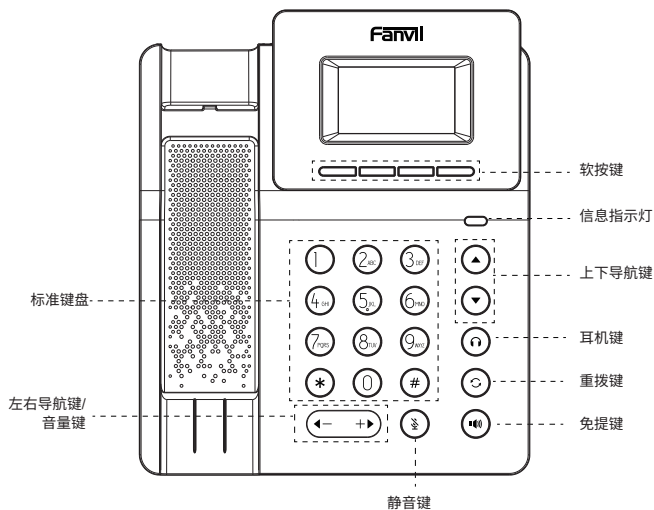

设备安装

请按照下面图片中的说明安装话机。

• 桌面支架安装

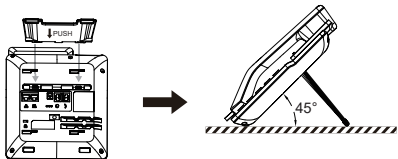
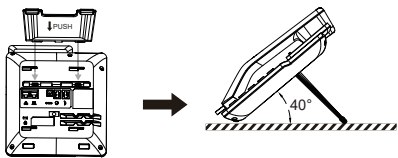

• 壁挂式安装

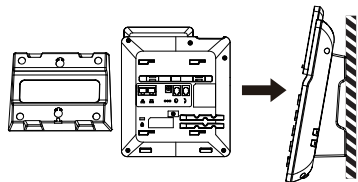

• 设备连接

请按下图说明将电源适配器，网络，PC，听筒，耳机连接到相应的端口。

- ① 电源接口：连接电源适配器。
- ② 网络接口：连接局域网或者互联网。
- ③ PC接口：连接电脑的网络接口。
- ④ 耳机接口：连接耳机。
- ⑤ 听筒接口：连接话机听筒。

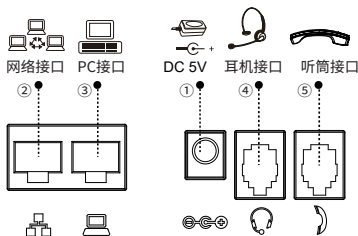

注意：如有其他需要的设置，请联系您的服务提供商，或下载用户手册和常见问题解答以获得更详细的配置说明。

网络连接

通过以太网连接

1. 打开设备电源，并将话机的广域网端口连接到集线器/交换机或路由器的RJ45插座，使用网线连接。
2. 默认为DHCP模式。

电话设置

通过话机LCD菜单配置

1. 按菜单键 > 高级 (默认密码 123)；
2. 选择网络 > 配置网络设置 (IPv4/IPv6/IPv4&IPv6, DHCP/静态IP/PPPoE)；
3. 选择账号：启用注册，并填写SIP服务器地址，端口，SIP用户名，密码等账号信息，注册新的SIP账号；
4. 保存配置。

通过网页配置

1. 从设备上获取IP地址：菜单 > 状态 > 以太网；
2. 登录：在网页浏览器上输入IP地址。电脑和电话应该处于同一个IP地址段，默认的用户名和密码都是“admin”；
3. 配置：选择网络/账号等，并填写相关内容；
4. 保存配置。

语言设置

1. 点击菜单 > 设置 > 语言设置。
2. 选择需要的语言，并按下确认软按键。

拨打电话

1. 预拨号：先输入电话号码，再拿起听筒。
2. 直接拨号：先拿起听筒，再输入电话号码。
3. 免提：先输入电话号码，再按下 ；顺序反之操作亦可。
4. 耳机：先输入电话号码，再按下 ；顺序反之操作亦可。
5. 指定线路拨号：按指定的线路键，输入电话号码，再按呼叫。

接听电话

1. 使用听筒接听：拿起听筒。
2. 使用耳机接听：按下 。
3. 使用免提接听：按下 。

重拨

1. 按下 键，重拨上一个呼叫号码。

通话静音

1. 按下 可在通话时关闭麦克风。
2. 按下 可恢复麦克风的使用。

Deutsch (DE)

Warnung

Warnung: Schalten Sie das Gerät während des Systemstarts oder Firmware-Upgrades nicht aus und wieder ein. Sie können Firmware-Images beschädigen und eine Fehlfunktion des Geräts verursachen.

Warnung: Verwenden Sie nur das im Lieferumfang des Geräts enthaltene Netzteil. Die Verwendung eines alternativen, nicht qualifizierten Netzteils kann das Gerät möglicherweise beschädigen.

Überblick

Das V50P ist ein elegantes, leistungsstarkes Business-IP-Telefon der Einstiegsklasse mit einem 132 x 64 Pixel großen Punktmatrix-Display, das 2 SIP-Leitungen und Audiokonferenzen für 6 Teilnehmer unterstützt, PoE-kompatibel und HD-Sprache ist. Es kann den Anwendungsszenarien verschiedener Unternehmen gerecht werden und den Benutzern eine hervorragende Interaktion sowie ein komfortables und sofortiges vernetztes Kommunikationserlebnis bieten.

Verpackungsliste

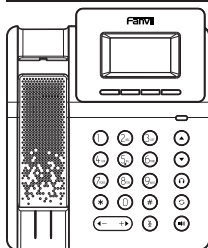

IP Telefon



Hörer



Hörer Kabel

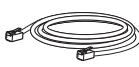

Ethernet-Kabel



QIG



Standfuß



Netzteil
(Optional)

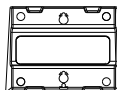

Wandmontagehalterung
(Optional)

Tastenbeschreibung

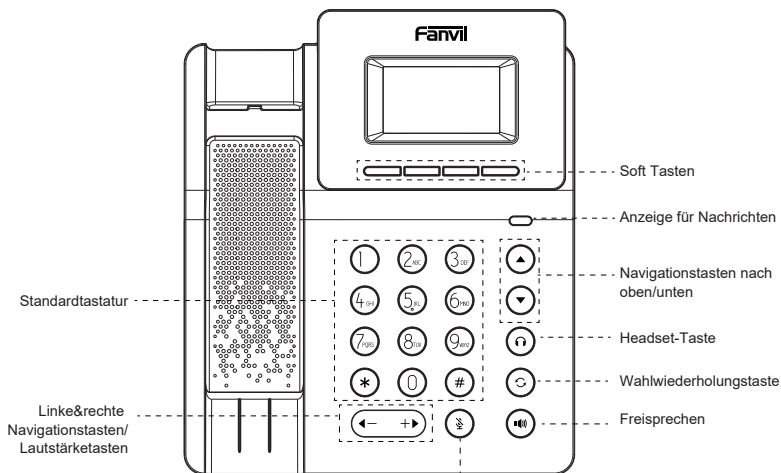

Installation

Bitte folgen Sie den untenstehenden Anweisungen

• Tischmontage

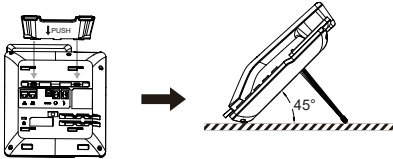
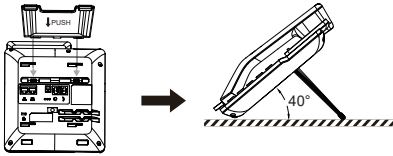

• Wandmontage

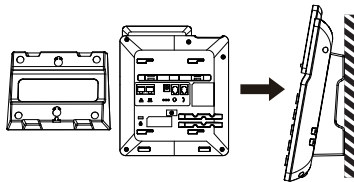

• Anbindung

Bitte schließen Sie das Netzteil, das Netzwerk, den PC, den Hörer und das Headset an die entsprechenden Anschlüsse an, wie in der Abbildung unten beschrieben.

- 1 Stromanschluss: Schließen Sie das Netzteil an.
- 2 Netzwerkanschluss: Anschluss eines lokalen Netzwerks oder das Internet.
- 3 PC-Anschluss: Der Netzwerkanschluss wird mit dem Computer verbunden.
- 4 Headset-Anschluss: Anschluss des Headsets.
- 5 Höreranschluss: Anschluss des IP-Telefon-Hörers.

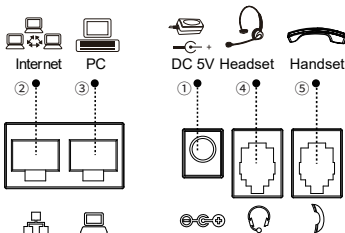

Netzwerkverbindung

Verwendung von Ethernet

1. Schalten Sie das Gerät ein und verbinden Sie den WAN-Port des Telefons über das Ethernet-Kabel mit der RJ45-Buchse eines Hubs/Switches oder eines Routers (LAN-Seite des Routers).
2. Die Standardeinstellung ist der DHCP-Modus.

Konfiguration

Konfiguration über das LCD-Menü des Telefons

1. Drücken Sie Menü > Erweitert (Standardpasswort 123).
2. Netzwerk wählen: Einstellungen von (IPv4/IPv6/IPv4&IPv6, DHCP/Static/PPPoE)
3. Um das Konto zu konfigurieren, geben Sie die Serveradresse, Port, Auth.Benutzernamen, Auth.Passwort usw. ein.
4. Speichern Sie die Konfiguration.

Konfiguration über Web

1. Rufen Sie die IP-Adresse von Ihrem Telefon ab: Menü > Status > ETH IP.
2. Geben Sie die IP-Adresse in den Webbrowser ein. Der PC und das Telefon sollten sich im gleichen IP-Adressensegment befinden (der Standard-Benutzername und Passwort ist "admin").
3. Konfigurieren: Netzwerk/Leitung usw. auswählen. und relevante Inhalte einfügen.
4. Speichern Sie die Konfiguration.

Spracheinstellung

1. Drücken Sie die Taste Menü > Basis > Sprache.
2. Wählen Sie die gewünschte Sprache und drücken Sie OK.

Anruf aufbauen

1. **Wahlvorbereitung:** Geben Sie die Nummer ein und nehmen Sie den Hörer ab.
2. **Direktwahl:** Heben Sie den Hörer ab und wählen Sie die Nummer.
3. **Freisprechen:** Geben Sie eine Telefonnummer ein und drücken Sie **1** .
4. **Headset:** Geben Sie eine Telefonnummer ein und drücken Sie **2** .
5. **Ausgewiesene Linie:** Leitungstaste drücken, Rufnummer eingeben und Wähltaste drücken.

Anruf annehmen

1. **Hörer:** Nehmen Sie den Hörer ab.
2. **Headset:** Drücken Sie **2** .
3. **Freisprechen:** Drücken Sie **1** .

Wahlwiederholung

1. Drücken Sie **3** um eine gewählte Nummer erneut zu wählen.

Anruf stummschalten

1. Drücken Sie **4** um das Mikrofon während eines Anrufs stummschalten.
2. Drücken Sie erneut **4** um die Stummschaltung des Mikrofons aufzuheben.

Hinweis: Wenden Sie sich für weitere Einstellungen zur Konfiguration des Telefons an Ihren Diensteanbieter oder laden Sie das Benutzerhandbuch und die häufig gestellten Fragen herunter, um detailliertere Informationen zu erhalten.

Español (ES)

Precauciones

Advertencia : Por favor, no apague el dispositivo durante el arranque del sistema o la actualización del firmware. Podría corromper las imágenes del firmware y causar un mal funcionamiento de la unidad.

Advertencia : Utilice únicamente el adaptador de corriente incluido en el paquete del dispositivo. El uso de un adaptador de corriente alternativo no calificado puede dañar la unidad.

Visión General

El V50P es un teléfono IP básico, elegante y de alto rendimiento. Cuenta con una pantalla monocromática de matriz de puntos de 132x64, soporta 2 líneas SIP y conferencias de voz de hasta 6 participantes, y es compatible con PoE integrado. Además, ofrece audio HD, lo que lo hace adecuado para una gran variedad de escenarios de aplicaciones empresariales, ofreciendo a los usuarios una excelente experiencia interactiva y cómodos servicios de comunicación instantánea.

Lista de embalaje

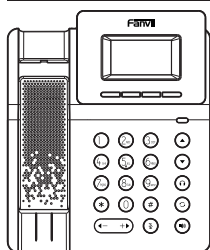

Teléfono IP



Auricular



Cordón del auricular



Cable Ethernet

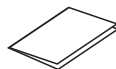

Guía de instalación rápida



Soporte de Escritorio

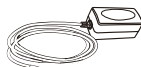

Adaptador de corriente (Opcional)

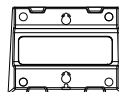

Soporte de pared (Opcional)

Descripción de las teclas

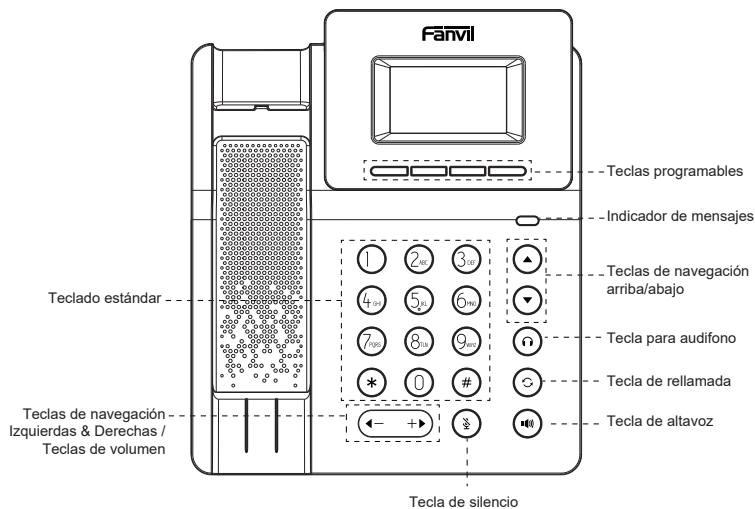

Instalación del dispositivo

Siga las instrucciones en la imagen a continuación para instalar el dispositivo.

• Montaje en sobremesa

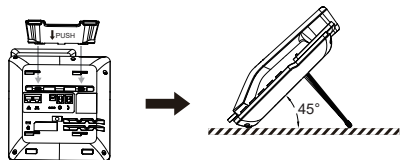
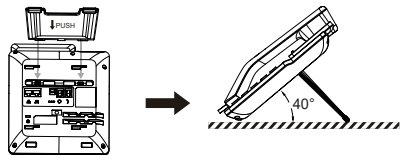

• Montaje en pared

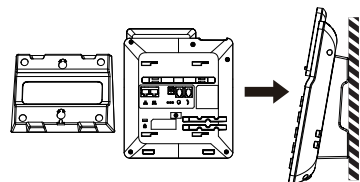

• Conéctese al dispositivo

Conecte el adaptador de corriente, la red, la PC, el teléfono y los auriculares al puerto correspondiente que se muestra a continuación

- 1 Puerto de alimentación: conecta el adaptador de corriente.
- 2 Puerto de red: conexión de red de área local o Internet.
- 3 Puerto PC: el puerto de red se conecta a la computadora.
- 4 Puerto de audífonos: conecta los audífonos.
- 5 Puerto del auricular: conecta el auricular del teléfono IP.

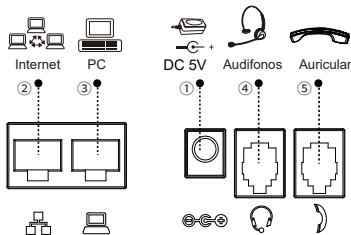

Conexión de red

Uso de Ethernet

1. Encienda el dispositivo y conecte el puerto WAN del teléfono a la toma RJ45 de un concentrador/conmutador o un enrutador (lado LAN del enrutador) usando el cable Ethernet.
2. El valor predeterminado es el modo DHCP.

Configuración del teléfono

Configuración a través del menú LCD del teléfono móvil

1. Presione Menú > Avanzado (contraseña predeterminada 123).
2. Selección Red: Configurar ajustes de red (IPv4/IPv6/IPv4 e IPv6, DHCP/Estático/PPPoE).
3. Seleccionar cuenta: para configurar la cuenta habilitada, ingrese la dirección del servidor SIP, el puerto, el nombre de usuario, la contraseña, etc.
4. Guarde la configuración.

Configuración vía web

1. Obtenga la dirección IP del dispositivo: Menú>Estado>ETH IP.
2. Iniciar sesión: ingrese la dirección IP en su navegador web. PC y el teléfono debe estar en el mismo segmento de dirección IP (El nombre de usuario y la contraseña predeterminados son 'admin').
3. Configurar: seleccione red/línea, etc. y complete el contenido relevante.
4. Guarde la configuración.

Configuración de idioma

1. Presione la tecla Menú > Básico > idioma.
2. Seleccione el idioma deseado y presione la tecla suave OK.

Haciendo una llamada

1. **Marcación previa:** introduce el número de teléfono y levante el auricular.
2. **Marcación directa:** levante el auricular e introduce el número de teléfono.
3. **Manos libres:** introduce el número de teléfono y pulsa o viceversa.
4. **Auriculares:** introduce el número de teléfono y pulsa o viceversa.
5. **Especifique la línea:** presione el botón de línea, introduzca el número de teléfono y presione el botón de marcación.

Responder una llamada

1. **Usar el teléfono:** tomar el auricular.
2. **Para usar los auriculares:** presione .
3. **En altavoz:** presione .

Marcar de nuevo

1. Pulse el botón para volver a marcar el número llamar.

Silencio durante la llamada

1. Presione la tecla para silenciar el micrófono durante una llamada.
2. Presione la tecla otra vez para reactivar el micrófono.

Nota: Puede ponerse en contacto con el técnico que instaló el producto para cualquier configuración adicional que pueda necesitar para configurar su teléfono, o descargar el manual del usuario y las preguntas frecuentes para obtener información más detallada.

Français (FR)

Précautions

Avvertissement: Ne coupez pas l'alimentation pendant le démarrage du système ou la mise à niveau du firmware. Vous risquez d'endommager l'image du firmware et de provoquer une défaillance de l'unité.

Avvertissement: Utilisez uniquement l'adaptateur inclus dans le pack. L'utilisation d'un autre adaptateur d'alimentation non conforme peut endommager l'unité.

Aperçu

Le V50P est un téléphone IP professionnel d'entrée de gamme élégant et performant, doté d'un écran matriciel à points de 132x64 pixels, prenant en charge 2 lignes SIP et des conférences audio à 6 participants, compatible avec l'alimentation PoE et la voix HD. Il peut répondre aux scénarios d'application de différentes entreprises et offrir aux utilisateurs une interaction supérieure et une expérience de communication interconnectée confortable et instantanée.

Contenu

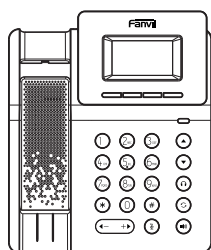

Téléphone



Combiné

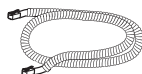

Cordon du combiné



Câble Ethernet



Guide d'installation rapide



Support de bureau



Adaptateur secteur
(facultatif)

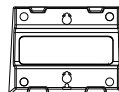

Support de montage mural
(facultatif)

Description des touches

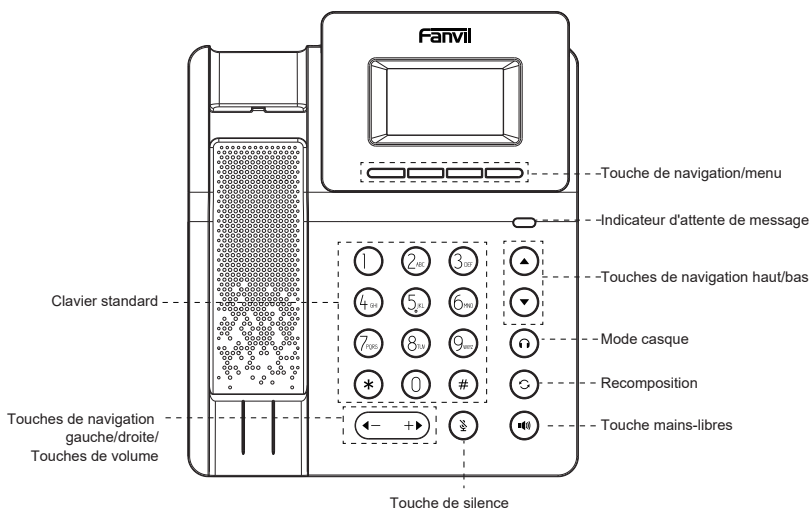

Installation des équipements

Veuillez suivre les instructions de l'image ci-dessous pour installer l'appareil.

• Fixation sur bureau

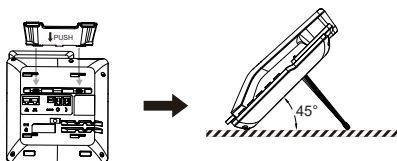
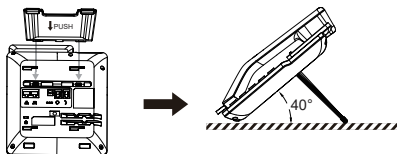

• Fixation murale

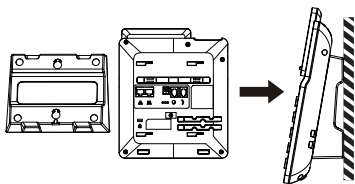

• Se connecter à un appareil

Connectez l'adaptateur secteur, le réseau, le PC, le combiné et le casque aux ports correspondants décrits dans la figure ci-dessous.

- 1 Port d'alimentation: Connectez l'adaptateur d'alimentation.
- 2 Port réseau: Connectez-vous au LAN ou à Internet.
- 3 Port PC: Connectez-vous au port réseau de l'ordinateur.
- 4 Port casque: Connectez le casque.
- 5 Port combiné: Connectez le combiné.

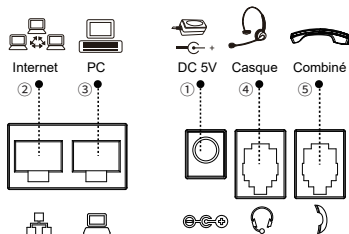

Connexion au réseau

Utilisation d'Ethernet

1. Allumez l'appareil et connectez le port WAN du téléphone à la prise RJ45 d'un concentrateur/commutateur ou d'un routeur (via le port LAN) à l'aide du câble Ethernet.
2. Le mode DHCP est sélectionné par défaut.

Configuration du téléphone

Configuration via le menu LCD du téléphone

1. Appuyez sur Menu > Avancé (mot de passe par défaut 123).
2. Sélectionnez Réseau: Configurez les paramètres réseau (IPv4/IPv6/IPv4 et IPv6, DHCP/Static/PPPoE).
3. Sélectionner un compte: Pour configurer un compte activé, renseignez l'adresse du serveur SIP, le port, le nom d'utilisateur, le mot de passe, etc.
4. Enregistrez la configuration.



Configuration via web

1. Obtenez l'adresse IP du téléphone : appuyez sur Menu > Statut > ETH IP/Wi-Fi IP.
2. Connexion: Entrez votre adresse IP dans votre navigateur web. Le PC et le téléphone doivent être dans le même segment d'adresse IP (le nom d'utilisateur et le mot de passe par défaut sont tous deux 'admin'.)
3. Configurer : sélectionnez le réseau/ligne, etc., et remplissez le contenu approprié.
4. Enregistrez la configuration.



Paramètres de la langue

1. Appuyez sur la touche Menu > Basic > Langue.
2. Sélectionnez la langue désirée et appuyez sur la touche OK.

Appel téléphonique

1. **Pré-composition**: Entrez le numéro de téléphone et décrochez votre combiné.
2. **Composition directe**: Soulevez votre combiné et entrez le numéro de téléphone.
3. **Mains libres**: Entrez le numéro de téléphone et appuyez sur  ou vice versa.
4. **Casque**: Entrez le numéro de téléphone et appuyez sur  ou vice versa.
5. **Spécifiez la ligne**: Appuyez sur la touche de ligne, entrez le numéro de téléphone et appuyez sur la touche de numérotation.



Répondre aux appels

1. **Utilisation du combiné**: Prenez le combiné.
2. **Utilisation du casque**: Appuyez sur .
3. **Pour utiliser le mode mains libres**: Appuyez sur .

Recomposition

1. Appuyez sur la touche  et recomposez le numéro

Mise en sourdine pendant l'appel

1. Appuyez sur  pour couper le microphone pendant un appel.
2. Appuyez sur  à nouveau pour réactiver le microphone.

Remarque: Vous pouvez contacter votre fournisseur de services pour obtenir les paramètres supplémentaires nécessaires à l'installation du téléphone, ou télécharger le manuel d'utilisation et la FAQ pour plus d'informations.

Italiano (IT)

Precauzioni

Avvertenza: non spegnere e riaccendere il dispositivo durante l'avvio del sistema o l'aggiornamento del firmware. Si possono danneggiare le immagini del firmware e causare il malfunzionamento dell'unità.

Avvertenza: Utilizzare solo l'alimentatore incluso nella confezione del dispositivo. L'utilizzo di un alimentatore alternativo non qualificato potrebbe danneggiare l'unità.

Panoramica

Il V50P è un telefono IP aziendale entry-level, elegante e performante, con schermo dot-matrix da 132x64 pixel, supporto per 2 linee SIP e conferenza audio a 6 vie, alimentazione PoE e voce HD. È in grado di soddisfare gli scenari applicativi di diverse aziende e di fornire agli utenti un'eccellente interazione e una comoda esperienza di comunicazione istantanea via Internet.

Contenuto della confezione

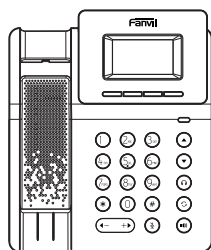

Telefono



Ricevitore



Cavo ricevitore



Cavo Ethernet

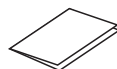

Manuale di
installazione rapida



Supporto



Adattatore di alimentazione
(opzionale)

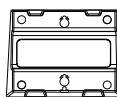

Staffa per il montaggio
a parete
(opzionale)

Descrizione delle funzioni dei tasti

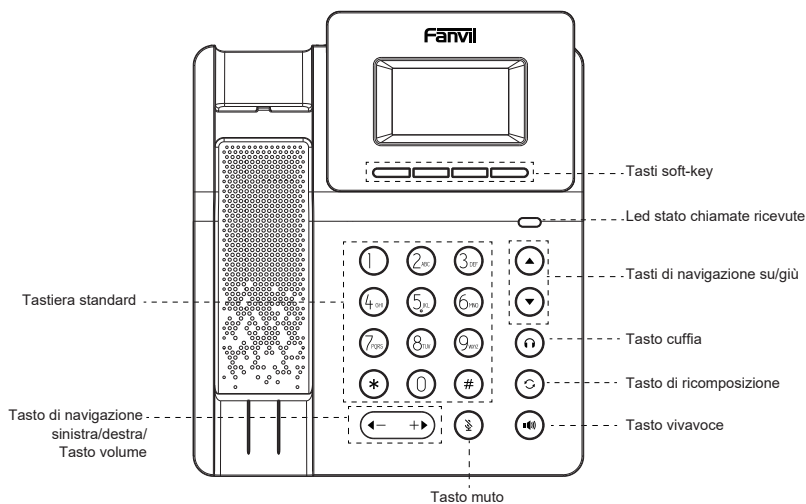

Installazione del dispositivo

Installare il dispositivo seguendo le istruzioni nella figura seguente.

• Metodo di montaggio su scrivania

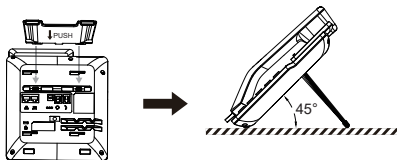
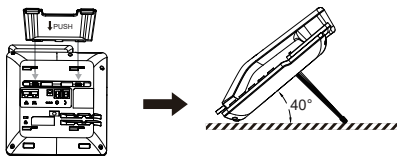

• Metodo di montaggio a parete

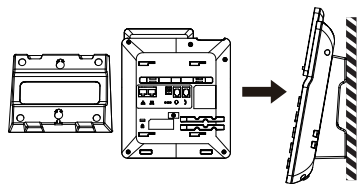

• Connetti al dispositivo

Collegare l'adattatore di alimentazione, la rete, il PC, la cornetta e le cuffie alla porta corrispondente descritta nella figura seguente.

- 1 Porta di alimentazione: collegare l'adattatore di alimentazione.
- 2 Porta di rete: Connessione alla LAN o a Internet.
- 3 Porta PC: Porta di rete per connettersi al computer.
- 4 Porta cuffie: Collegare le cuffie.
- 5 Porta microtelefono: Collegare la cornetta.

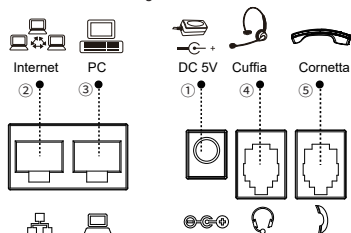

Connessione di rete

Connessione via cavo Ethernet

1. Accendere il dispositivo e collegare la porta WAN del telefono alla presa RJ45 di un hub/switch o di un router (lato LAN del router) utilizzando il cavo Ethernet.
2. L'impostazione predefinita è DHCP.

Configurazione del telefono

Configurazione tramite menù LCD del telefono

1. Premere Menu > Sistema (password predefinita 123).
2. Selezionare Network: Configura le impostazioni di rete (IPv4/IPv6/IPv4 e IPv6, DHCP/Static/PPPoE).
3. Seleziona account: per configurare l'account abilitato, inserire l'indirizzo del server SIP, la porta, il nome utente, la password, ecc.
4. Salva la configurazione.

Configurazione via web

1. Ottenere l'indirizzo IP dal telefono: Menu > Stato > ETH IP.
2. Login: inserisci l'indirizzo IP nel tuo browser web. PC e telefono dovrebbero trovarsi nello stesso segmento di indirizzo IP (il nome utente e la password predefiniti sono 'admin').
3. Configurare: Selezionare la rete/linea ecc. e inserire i contenuti pertinenti.
4. Salva la configurazione.

Impostazione della lingua

1. Premere Menu > Base > Lingua.
2. Seleziona la lingua desiderata e premi il tasto funzione OK.

Esecuzione di una chiamata

1. **Pre-composizione:** inserisci il numero di telefono e alza il ricevitore.
2. **Composizione diretta:** sollevare il ricevitore e inserire il numero di telefono.
3. **In vivavoce:** inserisci il numero di telefono e premi o viceversa.
4. **Cuffie:** inserisci il numero di telefono e premi o viceversa.
5. **Specificare la linea:** premere il pulsante di linea, inserire il numero di telefono e premere il pulsante di composizione.

Risposta a una chiamata

1. **Usa il telefono:** prendi il ricevitore.
2. **Per usare le cuffie:** premere .
3. **In vivavoce:** premere .

Ricomponi

1. Premere il pulsante o per ricomporre il numero chiamato.

Mute durante la chiamata

1. Premere per disattivare il microfono durante la chiamata.
2. Premere di nuovo per riattivare il microfono.

Nota: è possibile contattare il tecnico che ha installato il prodotto per ulteriori impostazioni che potrebbero essere necessarie per configurare il telefono o scaricare il manuale utente e le domande frequenti per informazioni più dettagliate.

Português (PT)

Precauções

Aviso: Não desligue e ligue o dispositivo durante a inicialização do sistema ou atualização do firmware. Você pode corromper arquivos de firmware e causar que a unidade tenha problemas.

Aviso: Use apenas o adaptador de energia incluído no embalagem do dispositivo. O uso de um adaptador de energia alternativo não qualificado pode danificar a unidade.

Visão geral

O V50P é um telefone IP empresarial elegante e de alto desempenho com uma tela de matriz de pontos de 132x64 pixels, suporte para 2 linhas SIP e conferência de áudio de 6 vias, suporte para fonte de alimentação PoE e voz HD. Ele pode atender aos cenários de aplicação de diferentes empresas e fornecer aos usuários uma excelente interação e uma experiência confortável de comunicação instantânea na Internet.

Lista de Embalagem

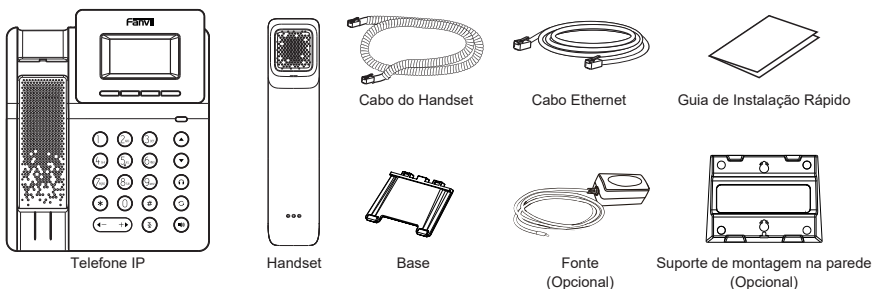

Descrição das Teclas

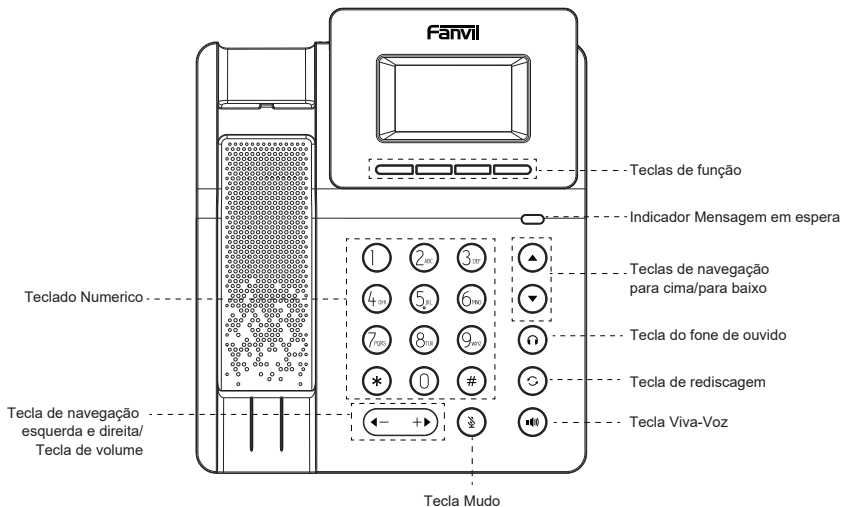

Instalação do dispositivo

Siga as instruções na imagem abaixo para instalar o dispositivo.

• Método de montagem na mesa

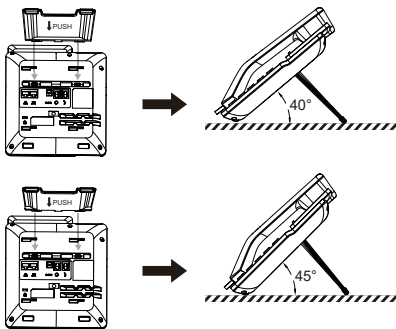

• Método de montagem na parede

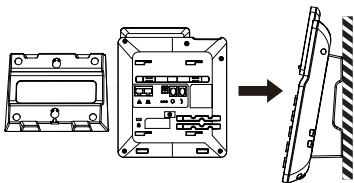

• Ligar o dispositivo

Conecte o adaptador de energia, rede, PC, headset e fone de ouvido às portas correspondentes, conforme é descrito na imagem abaixo.

1. Porta de energia DC 5V: Ligar o adaptador de energia.
2. Porta de rede Ethernet: Ligar na rede LAN ou Internet.
3. Porta PC: Porta de rede para fornecer conexão de Internet ao computador.
4. Porta de fone de ouvido: Ligar o fone de ouvido.
5. Porta do headset: Ligar o headset.

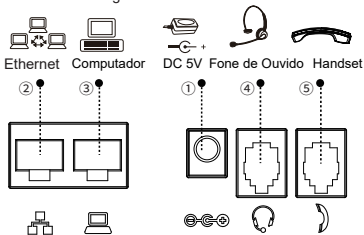

Conexão de rede

Usando Ethernet

1. Ligue o dispositivo e conecte a porta WAN do telefone ao soquete RJ45 de um hub/switch ou roteador (lado LAN do roteador) usando o cabo Ethernet.
2. O padrão é o modo DHCP.

Configuração do Telefone

Configuração via menu LCD do telefone

1. Pressione Menu > Advanced (senha padrão 123).
2. Seleção Rede: Para definir as configurações de rede (IPv4/IPv6/IPv4&IPv6, DHCP/Static/PPPoE).
3. Seleção Contas: Para configurar habilitar a conta, preencha o endereço do servidor SIP, porta, nome de usuário, senha etc.
4. Salve a configuração.

Configuração via web

1. Obter o endereço IP do telefone: Menu > Estado > ETH IP;
2. Login: Insira o endereço IP no navegador da web. O PC e o telefone devem estar no mesmo segmento de rede (o nome de usuário e a senha padrão são 'admin'.)
3. Configurar: Seleção rede/linha, etc, e preencha o conteúdo relevante.
4. Salve a configuração.

Configuração de Idioma

1. Pressione Menu > Básico > Idioma.
2. Seleção o idioma desejado e pressione a tecla OK.

Fazer uma chamada

1. **Pré-discagem:** digite o número do telefone e tire do handset.
2. **Discagem direto:** tire do handset e digite o número do telefone.
3. **Viva-Voz:** digite o número do telefone e pressione ou também vice versa.
4. **Fone de Ouvido:** digite o número do telefone e pressione ou também vice versa.
5. **Linha designada:** pressione a tecla de linha, digite o número do telefone e pressione a tecla de discagem.

Atender uma chamada

1. **Usando o handset:** tire do handset.
2. **Usando o fone de ouvido:** pressione .
3. **Usando o viva-voz:** pressione .

Rediscagem

1. Pressione a tecla , para rediscar o número de chamada.

Silêncio durante a chamada

1. Pressione para silenciar o microfone durante a chamada.
2. Pressione novamente para ativar o som da conversa.

Note: Você pode entrar em contato com seu provedor de serviços para obter configurações adicionais que possam ser necessárias para configurar o telefone ou também descarregar o manual do usuário e perguntas frequentes para obter informações mais detalhadas.

Any Changes or modifications not expressly approved by the party responsible for compliance could void the user's authority to operate the equipment.

This device complies with part 15 of the FCC Rules. Operation is subject to the following two conditions: (1) This device may not cause harmful interference, and (2) this device must accept any interference received, including interference that may cause undesired operation.

Note: This equipment has been tested and found to comply with the limits for a Class B digital device, pursuant to part 15 of the FCC Rules. These limits are designed to provide reasonable protection against harmful interference in a residential installation. This equipment generates, uses and can radiate radio frequency energy and, if not installed and used in accordance with the instructions, may cause harmful interference to radio communications. However, there is no guarantee that interference will not occur in a particular installation. If this equipment does cause harmful interference to radio or television reception, which can be determined by turning the equipment off and on, the user is encouraged to try to correct the interference by one or more of the following measures:

- Reorient or relocate the receiving antenna.
- Increase the separation between the equipment and receiver.
- Connect the equipment into an outlet on a circuit different from that to which the receiver is connected.
- Consult the dealer or an experienced radio/TV technician for help.

1.This equipment complies with Part 68 of the FCC rules and the requirements adopted by the ACTA. On the bottom of this equipment is a label that contains, among other information, a product identifier in the format US: 311IPNANV60W. If requested, this number must be provided to the telephone company.

2.A plug and jack used to connect this equipment to the premises wiring and telephone network must comply with the applicable FCC Part 68 rules and requirements adopted by the ACTA. A compliant telephone cord and modular plug is provided with this product. It is designed to be connected to a compatible modular jack that is also compliant. See installation instructions for details.

3.If this equipment [US: 311IPNANV60W] causes harm to the telephone network, the telephone company will notify you in advance that temporary discontinuance of service may be required. But if advance notice isn't practical, the telephone company will notify the customer as soon as possible. Also, you will be advised of your right to file a complaint with the FCC if you believe it is necessary.

4.The telephone company may make changes in its facilities, equipment, operations or procedures that could affect the operation of the equipment. If this happens the telephone company will provide advance notice in order for you to make necessary modifications to maintain uninterrupted service.

5.If trouble is experienced with this equipment [US: 311IPNANV60W], for repair or warranty information, Service can be facilitated through our office at:

U.S. Agent Company name: EMCTEK

Address: 11788 Big Canyon Ln, San DiegoCA 92131 USA

Tel: +1 858 401 9073

Fax: N/A

If the equipment is causing harm to the telephone network, the telephone company may request that you disconnect the equipment until the problem is resolved.

6.Please follow instructions for repairing if any (e.g. battery replacement section); otherwise do not alternate or repair any parts of device except specified. For repair procedures, follow the instructions outlined under the limited warranty.

7.Connection to party line service is subject to state tariffs. Contact the state public utility commission, public service commission or corporation commission for information.

8.If your home has specially wired alarm equipment connected to the telephone line, ensure the installation of this does not disable your alarm equipment. If you have questions about what will disable alarm equipment, consult your telephone company or a qualified installer.

9.If the telephone company requests information on what equipment is connected to their lines, inform them of:

- a)The ringer equivalence number [NAN]
- b)The USOC jack required [N/A]
- c)Facility Interface Codes ("FIC") [N/A]
- d)Service Order Codes ("SOC") [N/A]
- e)The FCC Registration Number [US: 311IPNANV60W]

10.The REN is used to determine the number of devices that may be connected to a telephone line. Excessive RENs on a telephone line may result in the devices not ringing in response to an incoming call. In most but not all areas, the sum of RENs should not exceed five (5.0). To be certain of the number of devices that may be connected to a line, as determined by the total RENs, contact the local telephone company. The REN for this product is part of the product identifier that has the format US: 311IPNANV60W. The digits represented by ## are the REN without a decimal point. For this product the FCC Registration number is [US: 311IPNANV60W] indicates the REN would be NAN.

11.We suggest the customers use a surge arrester to protect the device.



Fanvil Technology Co., Ltd

Website: www.fanvil.com

E-Mail: sales@fanvil.com support@fanvil.com

Tel: +86-755-2640-2199 Fax: +86-755-2640-2618

Add: 10/F Block A, Dualshine Global Science Innovation Center, Honglang North 2nd Road, Bao'an District, Shenzhen, China